

**Global engineering –
Trusted solutions**



OWNER'S MANUAL

Dustfree, portable blast machine

HS-200P-1

Clemco
International GmbH

Carl-Zeiss-Straße 21
83052 Bruckmühl
Germany

Tel.: +49 (0) 8062 – 90080
Mail: info@clemco.de
Web: www.clemco-international.com

TABLE OF CONTENTS

1	SCOPE OF MANUAL	3
2	APPLICATION AND RESTRICTIONS	3
3	GENERAL DESCRIPTION.....	3
3.1	COMPONENTS	3
3.2	AIR REQUIREMENTS.....	5
3.3	HOW THE SYSTEM WORKS.....	5
4	INSTALLATION	6
4.1	SET-UP FOR INITIAL INSTALLATION OR REINSTALLATION	6
4.2	DAILY SET-UP.....	7
4.3	OPERATION	8
4.4	SHUT DOWN.....	8
4.5	SHUT DOWN WHEN MOVING EQUIPMENT	9
5	MAINTENANCE	9
5.1	GENERAL.....	9
5.2	DAILY CHECK LIST	9
5.3	WEEKLY CHECK LIST.....	9
5.4	MONTHLY CHECK LIST.....	10
6	TROUBLE-SHOOTING	10
7	REPLACEMENT PARTS	12
7.1	SYSTEM.....	12
7.2	BLAST HEAD EDBH 70 AND 90-I.....	15
7.2.1	Blast head EDBH 70.....	15
7.2.2	Blast head EDBH 90-I.....	16
7.3	REVERSE PULSE DUST COLLECTOR	17

1 Scope of manual

This manual covers set-up, operation and maintenance of the dustfree, portable blast machine HS-200P-1.

Additionally the owner's manual "Remote control valves RMS-2000, 1500, 500" should be considered.

2 Application and restrictions

This dustfree blast machine is mainly applied for blast cleaning of parts which cannot be blasted in a cabinet or blast room (because of their size, weight or long distance for transportation). The design allows local blast cleaning on a part without the escape of abrasive, dust or debris into the environment. All type of blast media can be used. When using glass beads or plastic media a special design for the impact separator is necessary.

The blast machine is rated for a **maximum working pressure of 8 bar**.

3 General description

3.1 Components



Figure 1 HS 200 P-1.

Figure 1 shows the major components:

- *Chassis* (L x B x H = 1.400 x 790 x 2.200 mm, weight approx. 300 kg) with mounted
 - pot and silo.
 - reverse pulse dust collector.
 - air manifold.

- *Pot with integrated silo*
 - Volume 40l each (pot and silo respectively).
 - Maximum working pressure 12 bar.
 - 60 degree cone.
 - Abrasive metering valve
 - Removable screen.
 - Impact separator with rubberized plate (for glass beads and plastic media on request).

- *Reverse pulse dust collector with*
 - filter cartridge (filter area 8 m²).
 - suction unit.
 - dust container.

- *Air manifold with*
 - 1 inlet valve RMS-1500.
 - air relief valve.
 - moisture separator.
 - air connection.

- *Blast head EDBH-90-1 or EDBH-70*
 - Nozzle SMR-4 (standard).
 - Nozzle CSD-4/B (boron carbide) for aluminium oxide.
 - Flat and elbow brush.

- *Hoses between pot / silo und blast head*
 - ⇒ PU-suction hose 2" with couplings.
 - ⇒ Blast hose 25 x 7 mm or 19 x 7 mm with couplings.

- Deadman handle with twinline hoses (mounted on blast hose).

- 3-way slide valve (suction unit On / Off) with twinline hose.

3.2 Air requirements

Air consumption suction unit: approx. **4,3 m³/min.** at **8 bar**.

Air consumption with **6,5 mm** nozzle: approx. **3 m³/min.** at **7 bar**.

3.3 How the system works

(See Figure 2: Plumbing assembly.)

When the air supply is on, compressed air enters the air manifold via the moisture separator (item 1).

When the **3-way slide valve** (item 18) is **closed**, the **right inlet valve RMS-1500** (item 2) **opens** and **frees** the **supply air** for the **suction unit** (item 20) and the **deadman handle** (item 17). The suction unit turns on.

When the **deadman handle** (item 17) is **depressed**, the **outlet valve** (item 6) **closes**, and the pot is pressurized (pop-up valve item 4 closes). The **blast process starts**. The **working pressure** is adjusted with the **pressure regulator** (item 3).

After hitting the surface **abrasive** and **debris** are **drawn into** the **blast head** (item 16) and guided (suction hose item 15) to the **impact separator** (item 30). The coarse, reusable media is screened (item 10) and falls into the silo. The suction unit (item 20) draws the **dust into the reverse pulse dust collector** (item 23).

When the deadman handle is released (item 17), the **outlet valve** (item 6) **opens**, and the **blast process interrupts** (the pot is depressurized). The blast media in the silo falls through the filling port into the pot.

When the **3-way slide valve** (item 18) is **opened** the suction unit turns off and the **filter cartridge** is **cleaned** through a **pulse of compressed air**. With the **pressure regulator** (item 25) the air pressure for pulsing is adjusted (max. 7bar)

4 Installation

4.1 Set-up for initial installation or reinstallation

(1) <i>Place the blast machine.</i>	Firm and even ground.
(2) <i>Install air supply.</i>	<ul style="list-style-type: none"> – Start the compressor and bring it up to operating temperature (5 to 10 min.). Only use compressors whose rating do not exceed 8 bar! – Attach an air line (appropriate dimension) with all necessary gaskets in place to the air outlet of the compressor and safety lock the couplings. Escaping air is dangerous and lowers efficiency! – Carefully open the air valve of the compressor to blow debris and moisture out the attached air line. – Close the air valve. – Connect the air line to the blast machine and safety lock it. <p>For troublefree blasting we recommend an air supply free of oil and water (air cooler with cyclone and automatic drain).</p>
(3) <i>Connect the blast hose, suction hose and the remote control hoses.</i>	<ul style="list-style-type: none"> – Connect the blast and suction hose to the blast machine and safety lock them. – Check that all gaskets are in place. – Connect both twinline hoses (yellow / brown and red / blue) to the corresponding twinline hoses coming from the blast machine. <p>Attention! A reversed connection causes malfunction and danger of injuries!</p>
(4) <i>Choose the right brush.</i>	<ul style="list-style-type: none"> – Flat brush for flat surfaces. – Elbow brush for edges.
(5) <i>Put on the protective equipment.</i>	<ul style="list-style-type: none"> – Abrasive-resistant clothing. – Eye protection, for example goggles with safety glass. – Leather gloves.
(6) <i>Check moisture separator, pulse pressure and remove moisture from the blast machine.</i>	<ul style="list-style-type: none"> – Open the air valve of the compressor. – Open the ball valve. – Check pulse pressure (regulator knob with gauge on the suction unit). Maximum pressure 5 bar.

	<ul style="list-style-type: none"> - Adjust the drain of the moisture separator, so that a constant stream of liquid and air is expelled under pressure. - Fully open the media metering valve. - Close 3-way slide valve (suction unit turns on). - About 3 min. hold the deadman handle depressed (the pot is pressurized and air comes out the nozzle), in order to remove moist. - Release the deadman handle.
--	---

4.2 Daily set-up

Not necessary if an initial installation or reinstallation was performed (see section 4.1).

(1) <i>Install an air supply.</i>	<ul style="list-style-type: none"> - Start the compressor and bring it up to operating temperature (5 to 10 min.). Only use compressors whose rating do not exceed 8 bar! - Connect an air line to the compressor's air outlet and remove moist. - Install all necessary gaskets and safety lock the couplings. Escaping air is dangerous and lowers efficiency! - Connect the air line to the blast machine and safety lock it.
(2) <i>Put on the protective equipment.</i>	<ul style="list-style-type: none"> - Abrasive-resistant clothing. - Eye protection, for example goggles with safety glass. - Leather gloves.
(3) <i>Check the moisture separator, pulse pressure and remove moist from blast machine (longer standstill).</i>	<ul style="list-style-type: none"> - Open the air valve of the compressor. - Open the ball valve. - Check pulse pressure (regulator knob with gauge on the suction unit). Maximum pressure 5 bar. - Adjust the drain of the moisture separator, so that a constant stream of liquid and air is expelled under pressure. - Fully open the media metering valve. - Close 3-way slide valve (suction unit turns on).

	<ul style="list-style-type: none"> - Hold the deadman handle about 3 min depressed (the pot is pressurized and air comes out the nozzle), in order to remove moist. - Release the deadman handle.
--	---

4.3 Operation

(1) Load abrasive into the blast machine.	<p>Only when the blast machine is fully empty!</p> <ul style="list-style-type: none"> - Close metering valve (turn the metering knob to the right). - Pour abrasive (30 to 40L) on an even surface. - Close the 3-way slide valve (suction unit turns on) and through the blast head draw the abrasive into the blast machine (the abrasive will immediately be cleaned).
(2) Media metering. (2 persons are necessary).	<ul style="list-style-type: none"> - Place the blast head vertically on the work surface. - Close 3-way slide valve (suction unit turns on). - Depress deadman handle. - Second person slowly opens the metering valve until enough blast media comes out the nozzle (blast pattern and noise). - Release deadman handle.
(3) Operation.	<ul style="list-style-type: none"> - Place the blast head vertically on the work surface. - Depress deadman handle (the blast process starts). - Slowly move the blast head according to the blast progress.

4.4 Shut down

(1) Completely remove abrasive.	<p>Prevent blockage from moist abrasive (longer standstill of blast machine).</p> <ul style="list-style-type: none"> - Reduce working pressure to 0,5 bar. - Fully open the media metering valve. - Turn on suction unit (3-way slide valve). - Depress deadman handle. - Empty the abrasive into a container.
---------------------------------	--

4.5 Shut down when moving equipment

No special measures required.

5 Maintenance

5.1 General

During operation blast machines are exposed to wear. In order to ensure safe operation and high efficiency the blast machines should be maintained according to the following check lists.

Prior to maintenance, make sure that the air valve of the compressor is closed and the whole system is depressurized!

5.2 Daily check list

(1) Pot.	<ul style="list-style-type: none">– Open inspection door.– Check the gasket and the pop-up valve of the filling port by hand for wear.
(2) Air, suction and blast hose.	<ul style="list-style-type: none">– Check the hoses for sharp bends, causing high loss of energy and rapid wear. <p>No vehicles should pass over hoses!</p> <ul style="list-style-type: none">– Check the gaskets of the couplings.
(3) Nozzle.	<ul style="list-style-type: none">– Check the nozzle gasket and replace it at the first sign of wear.– Check the nozzle for wear and replace it if necessary.
(4) Remote control valves and accessories.	<ul style="list-style-type: none">– Open the petcock of the remote control valve RMS-1500 and check for water. If water is detected check the moisture separator (see section 5.3).– Check the fittings of the remote control valves for tightness.
(5) Dust container.	Empty dust container.

5.3 Weekly check list

(1) Moisture separator.	Remove and check the filter element. If necessary clean the filter and the sight glass with soap and warm water and dry it with compressed air.
	A dirty filter causes loss of pressure in the system!
(2) Air, suction and blast hoses.	<ul style="list-style-type: none">– Check all couplings and screws for wear or breakage and replace them if necessary.

	<ul style="list-style-type: none"> – Check the whole blast hose by hand for soft spots (reduced wall thickness) and replace it immediately when soft spots are detected. – Check the air line (air supply) and replace it when it is worn. – Check the gaskets of couplings for wear and replace them if necessary.
--	---

5.4 Monthly check list

(1) Remote control valve RMS-1500 respective outlet valve	Check all fittings and connections of the remote control valve for leakage.
--	---

6 Trouble-shooting

Problem	Probable cause	Remedy
(1) No air and no abrasive comes out the nozzle.	Turned off compressor.	Turn on compressor.
	Blocked moisture separator.	Check and clean.
	Inlet valve RMS-1500 doesn't work.	<ul style="list-style-type: none"> – Close 3-way slide valve. – Depress deadman handle. – Check valves and control hoses for loose connections.
(2) Air, but no abrasive comes out the nozzle.	Closed metering valve.	Open it.
	Moist abrasive blocks the flow of abrasive at the bottom of the pot.	<ul style="list-style-type: none"> – Several times open and close choke valve rapidly. – Open the inspection door and clean the pot.
	Not enough air volume.	Use a bigger compressor.
(3) Irregular flow of abrasive comes out the nozzle.	Incorrectly adjusted abrasive metering valve.	Check adjustments.
	Choke valve not fully opened.	Check and fully open it.
	Blocked metering valve.	Open and clean metering valve.

(4) <i>Too much abrasive comes out the nozzle.</i>	Metering valve too much opened.	Check and correct adjustments if necessary.
	Choke valve not fully opened.	Check and fully open it.
(5) <i>Pop-up valve doesn't remain closed.</i>	Not enough air volume or pressure.	<ul style="list-style-type: none"> – Check air pressure of the compressor with a needle gauge. – Close the choke valve. When the pop-up valve does not seal the filling port completely, there is not enough air volume.
(6) <i>Pop-up valve does not close after depressurization.</i>	Worn pop-up valve and / or gasket.	Replace the pop-up valve and / or the gasket.
	Blocked guide for the pop-up valve.	<ul style="list-style-type: none"> – Open inspection door. – Remove the pop-up valve and clean the blast machine.
(7) <i>Blast machine does not depressurize when the deadman handle is released.</i>	Blocked outlet valve.	Clean the outlet valve.
	Inlet valve RMS-1500 defective.	<ul style="list-style-type: none"> – Check connections. – Check and repair the inlet valve.
(8) <i>Poor suction (abrasive is not completely drawn into the blast machine and escapes).</i>	Not enough air volume or pressure.	<ul style="list-style-type: none"> – Check air pressure of the compressor with a needle gauge. – If necessary use a bigger compressor.
	Blocked moisture separator.	Check and clean.
	Clogged filter cartridge.	<ul style="list-style-type: none"> – Turn off the suction unit after a longer period of work without interruption (filter cartridge is cleaned). – Check pulse pressure. – Clean filter cartridge.

	Defective gaskets.	The following gaskets should be checked for wear and replaced: <ul style="list-style-type: none"> – Impact separator. – Dust collector.
(9) Suction unit cannot be turned on.	No air supply.	Install an air supply.
	Defective inlet valve RMS-1500.	Check and repair or replace if necessary.
	Defective pneumatic controls.	<ul style="list-style-type: none"> – Check all control hoses and connections for wear. – Check 3-way slide valve.

7 Replacement parts

7.1 System

(See Figure 2 - Replacements parts HS 200 P-1.)

No.	Stock No.	Model	Description
(-)	99954D	HS-200 P-1	Dustfree, portable blast machine complete
(1)	90545D	HMS	Moisture separator
(2)	100028	RMS-1500	Inlet valve complete
(3)	01906D		Pressure regulator 1¼"
(4)	02321D	P-2	Pop-up valve with external sleeve
(5)	99157D	P-5	Gasket
(6)	03371I	TLR	Outlet valve
(7)	100047	1"	Hose with SKG-25
(8)	02397D	1 ¼"	Ball valve
(9)	22780D	QK-Quantum	Abrasive metering valve
(-)	100832		Gasket (for impact separator)
(10)	99802D		Screen HSP
(11)	90554D	1 ½"	Ball valve
(12)	99702D	2"	Nipple 2" A
(13)	99180D	2"	Coupling
(14)	04351D	19 x 7	Blast hose 10 m
(-)	04305D	25 x 7	Blast hose 10 m
(15)	90067D	2"	Suction hose (PU)
(16)	94342D	EDBH-90-I	Blast head without nozzle

	99942D	EDBH-70	Blast head with nozzles
(17)	100707	RLX III	Pneumatic remote control handle
(18)	99172D	ACS	3-way slide valve
(19)	90734D		Twinline hose complete with couplings 10 m
(20)	99665D		Suction unit
(21)	99762D		Latch
(22)	99200D	ZP-P-15-8	Special filter (reverse pulse dust collector)
(23)	90953D		Filter cartridge
(24)	99946D		Dust container
(25)	99769D	1/4"	Pressure regulator
(26)	90024D	N460S	Nipple
(27)	99633D	1 1/4"	Non return valve
(28)	90067D		Suction hose 2" (PU)
(29)	90023D		Air relief valve 1"
(30)	99801D		Impact Separator HSP
((31)	100346	3/2 way	Valve
(-)	24217I	1/2"	Non-return ball valve
(-)	99096D	3/8"	T-pice
(-)	90038D	46/32	Nipple NW32
(-)	99641D	SK-51	Clamp
(-)	99767D		Wheel
(-)	99766D		Wheel steerable with brake
(-)	99676D		Hose package ==> 10 m suction hose 2" PU 10 m blast hose 25 x 7 or 19 x 7 10 m twinline hose complete with couplings

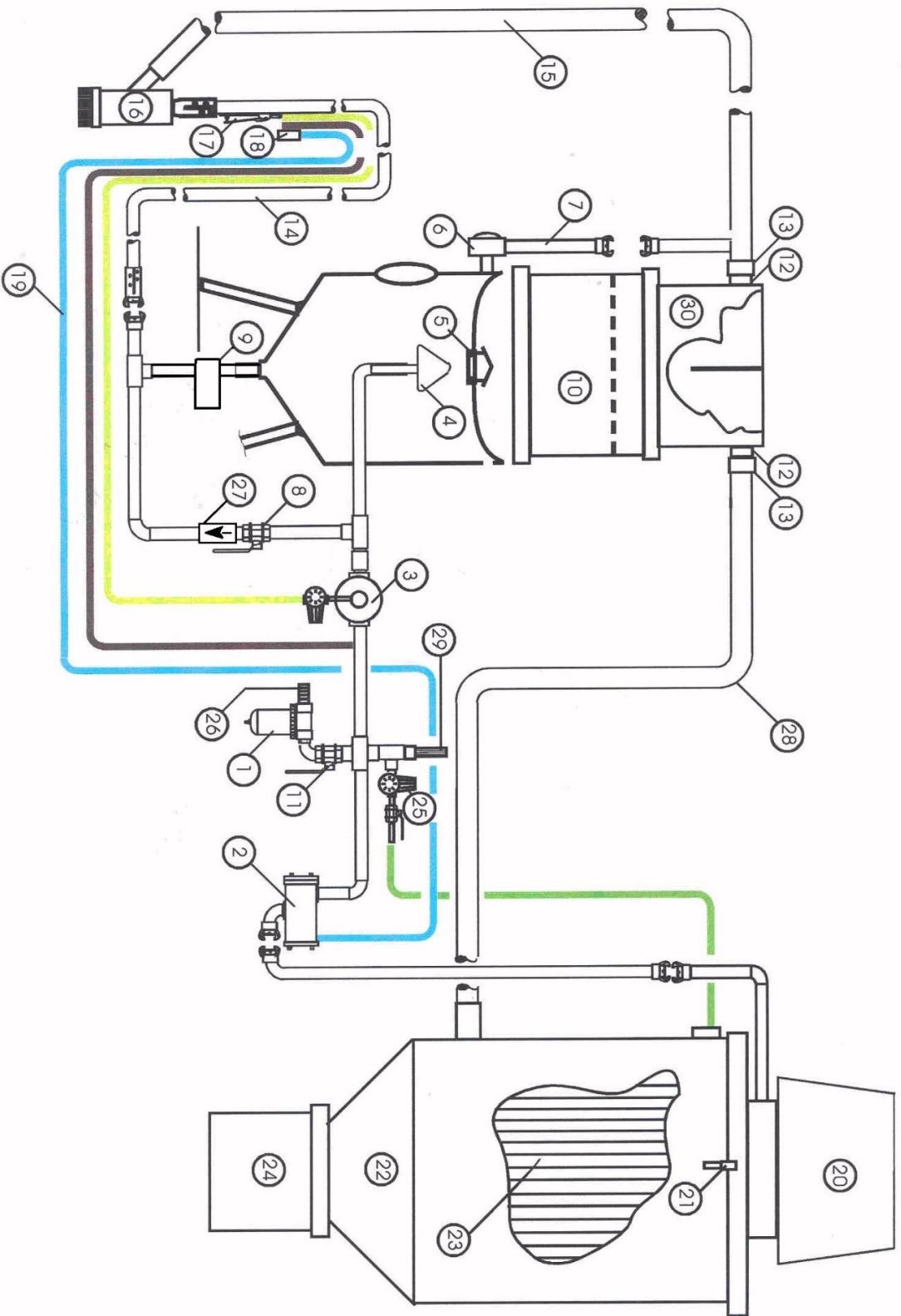

Figure 2 - Replacements parts HS 200 P-1

7.2 Blast head EDBH 70 and 90-I

7.2.1 Blast head EDBH 70

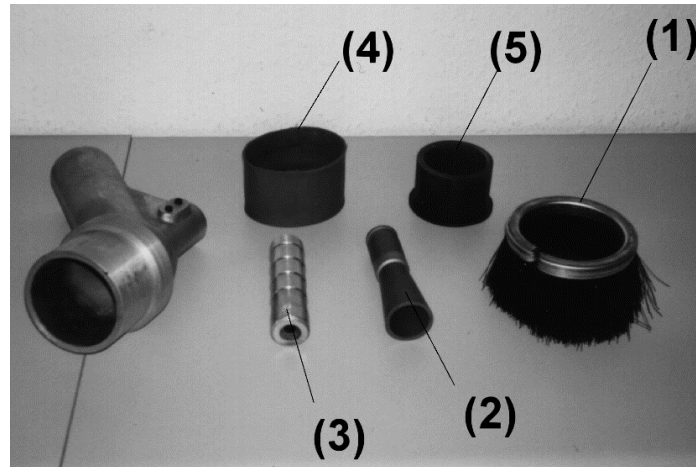

Figure 4 Replacement parts EDBH 70.

No.	Stock No.	Model	Description
(-)	99942D	EDBH-70	Blast head new with nozzles
(1)	99994D	70 mm	Flat brush for EDBH-70
(2)	99943D		Diffusor EDBH-70
(3)	94183D	CBST-25 x 6	Nozzle EDBH-70
(4)	99978D		Protection-rubber
(5)	99992D		Brush protection

7.2.2 Blast head EDBH 90-I

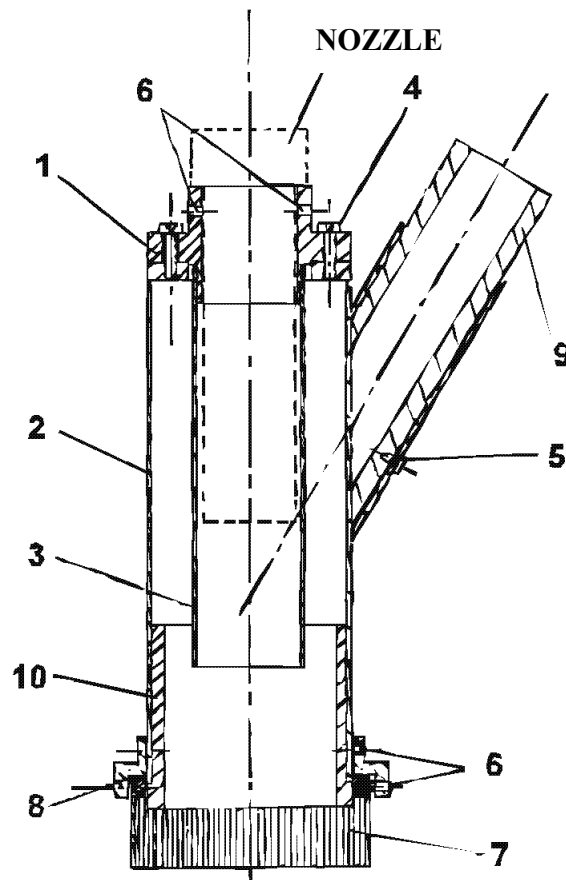

Figure 5 Replacement parts blast head EDBH 90-I.

No.	Stock No.	Model	Description
(-)	94342D1	EDBH 90-I	Blast head without nozzle
(1)	100148	ALU	Nozzle mounting plate
(2)	94342A	Stainless steel	Body
(3)	99504D	Stainless steel	Nozzle guard
(4)	90154D	M6 x 20	Hex. socket head screw
(5)	90294D		Screw for fastener
(6)	90110D	M5 x 8 mm	Grub screws
(7)	99182D	5"	Flat brush
	99183D		Elbow brush
(8)	100150		Brush holder
(9)	04256D	32 x 8	Hose
(10)	100087		Brush protection rubber
(-)	100864	SMS-4	Clemlite nozzle \varnothing 6,5 mm

7.3 Reverse pulse dust collector

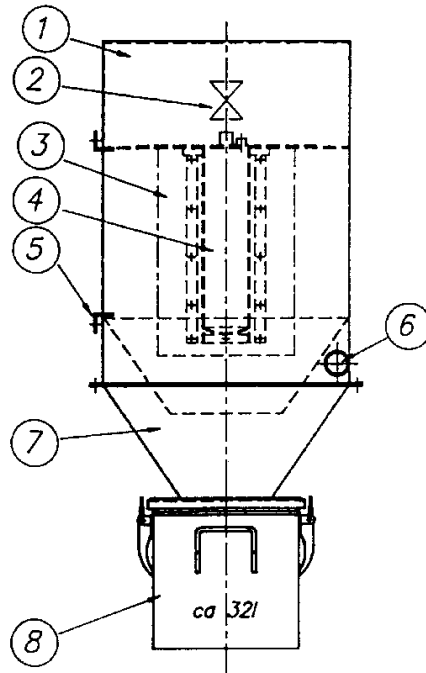

Figure 6 Cartridge filter.

No.	Stock No.	Model	Description
(-)	99200D	ZP-P-15-8	Special filter
(1)			Upper body
(2)			Diaphragm valve pneumatically operated
(3)	90953D		Filter cartridge
(4)			Air manifold
(5)			Hinges
(6)			Inlet manifold rubberized
(7)			Lower part rubberized
(8)			Dust container

The filter cleans in 2 stages:

Stage 1: Air and dust are drawn into the lower part (item 7) of the filter through the inlet manifold (item 6). Coarse material is separated (cyclone).

Stage 2: The fine material is separated through the filter cartridge (item 3). The filter cartridge is cleaned through a reverse pulse of compressed air when the suction unit is turned of.