

**Global engineering -
Trusted solutions**



OWNER'S MANUAL

Power-Injection-Gun **PIG**

Clemco

International GmbH

Carl-Zeiss-Straße 21
83052 Bruckmühl
Germany

Tel.: +49 (0) 8062 – 90080

Mail: info@clemco.de

Web: www.clemco-international.com

1 Scope of manual

This manual covers set-up, operation and maintenance of the Power-Injection-Gun.

2 Applications and restrictions

The Power-Injection-Gun can be used for all type of abrasives with a size < 1,5 mm. The **maximum working pressure** is **12 bar**.

Adequate performance can be reached with a media hose length of up to 10 m, a suction height of 4 m at a pressure of 7 bar (tested with steel grit < 0,8 mm).

The equipment is used for similiar applications as a pressure blast system although with a 15 to 20% lower efficiency. Its low weight and good handling makes it a perfect unit for small and fast changing on-site jobs as

- selected surface preparation on coated metal parts.
- removal of coatings and rust in areas to be welded.
- to create a rough surface for coatings or similar applications.
- subsequent blasting work on equipment already assembled with dimensions too big for a blast room.

Attention! The laws for environmental protection and operator's safety also have to be applied for this equipment!

3 General description

The Power-Injection Gun is a suction blast system optimized to provide a next to pressure blasting performance.

An air hose (item 7) and a media hose (item 6) are joined in the gun assembly. Air rushing at high velocity through the air jet (item 4) creates a partial vacuum in the mixer (item 3) and in the media hose (item 6). As a result, abrasive is sucked up from the hopper trough the suction lance (item 5) and propelled out the blast nozzle (item 2).

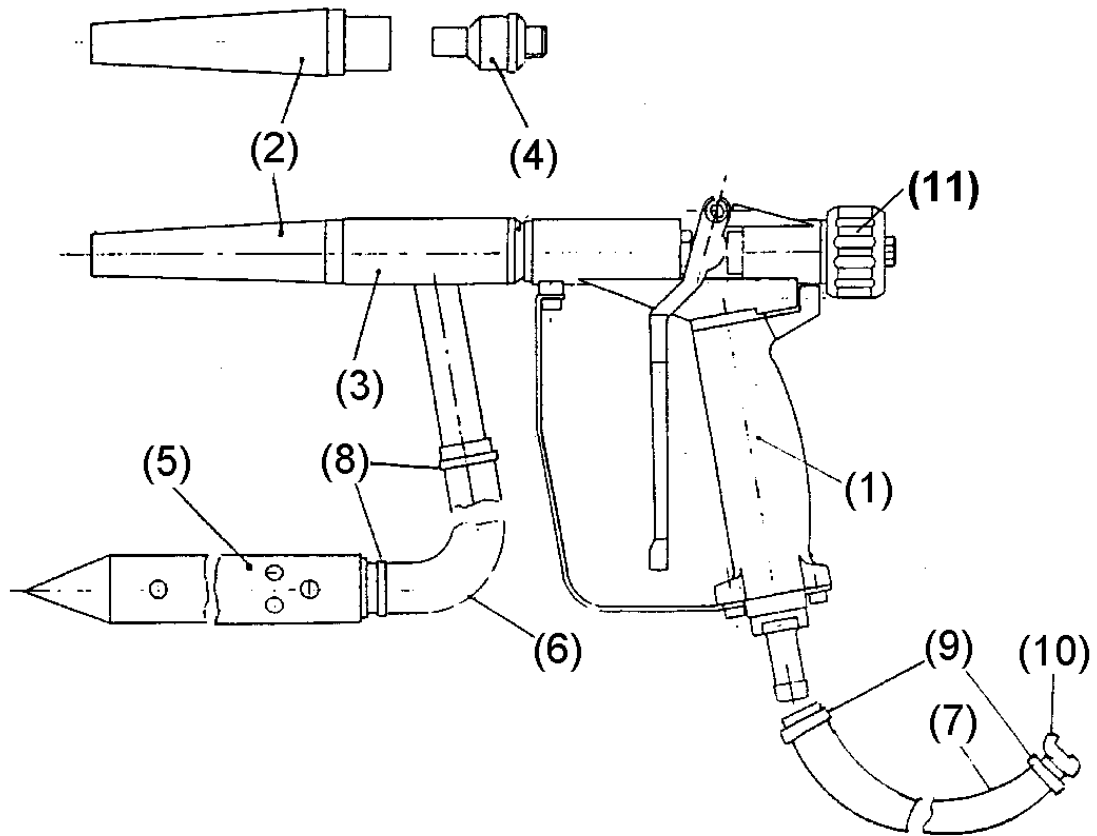

- (1) Handle with air valve
- (2) Nozzle
- (3) Mixer
- (4) Air jet / orifice assembly
- (5) Suction lance
- (6) Media hose
- (7) Air hose

- (8) Clamp for media hose
- (9) Clamp for air hose
- (10) Hose coupling SKG 19
- (11) Screws
- (12) Hopper (not shown)
- (13) Cart for hopper (not shown)

4 Installation

4.1 Air requirements

Pressure [bar]	3	4	5	6	7	8	9	10	11	12
Air consumption [m³/min]	2,4	3,0	3,6	4,2	4,8	5,4	6,1	6,7	7,3	8,0

4.2 Set-up for initial installation or reinstallation

When shipped the Power-Injection-Gun is ready installed. Only check the clamps for the air and the media hose.

4.3 Daily set-up

- (1) Check the equipment for loose connections and worn air or media hose.
- (2) Make sure there is enough room and illumination for blasting.
- (3) Locate the cart with the hopper on a firm level ground.
- (2) Start the compressor and bring it up to operating temperature (5 to 10 min).
- (3) Connect the air hose to the compressor and blow debris and moist out the hose.
- (4) Connect the air hose to the gun and install the suction lance on the hopper.

Make sure that the air holes of the suction lance are outside the hopper.

- (5) Put on the protective equipment
 - Blast suit.
 - Leather gloves.
 - Airfed helmet with breathing air filter.

4.4 Operation

- (6) Fill the blast media into the hopper.
- (7) Point the gun to the surface being blasted and squeeze the trigger. The blast process starts. For interruption release the trigger.

4.5 Shut down

- (8) Remove the suction lance from the hopper and remove the rest of the blast media still present in the media hose.
- (9) Close the air supply.

5 Maintenance

During operation the equipment is exposed to wear. In order to ensure safe operation and high efficiency it should be maintained according to the following check lists.

Prior to maintenance, make sure that the air valve of the compressor is closed and the whole system is depressurized!

5.1 Daily check list

(1) Check for loose connections.

5.2 Weekly check list

(1) Check for loose connections.

(2) Check the hoses for wear and replace them if necessary.

(3) Check the nozzle for wear. A diameter increase of 10% reduces the performance to 80%.

5.3 Monthly check list

(1) Check for loose connections.

(2) Check the hoses for wear and replace them if necessary.

(3) Check the nozzle for wear. A diameter increase of 10% reduces the performance to 80%.

(4) Check the mixer for wear and replace if it is necessary.

(5) Check the the orifice for wear. A 1 mm wear (length) of the orifice tremendously reduces the performance iof the equipment.

6 Trouble-shooting

<i>Problem</i>	<i>Probable cause</i>	<i>Remedy</i>
(1) Air but no blast media comes out the nozzle.	Moist abrasive or obstruction.	<ul style="list-style-type: none"> – Pull the suction lance out of the hopper. – Seal the nozzle outlet. – Squeeze the trigger (the air reverses its direction and cleans the gun body and the media hose. – Otherwise clean the mixer, the suction lance and the media hose. – Change the abrasive.
	Leaking media hose.	<ul style="list-style-type: none"> – Tighten the clamps of the media hose. – Replace worn media hose. – Replace worn mixer.

7 Replacement parts

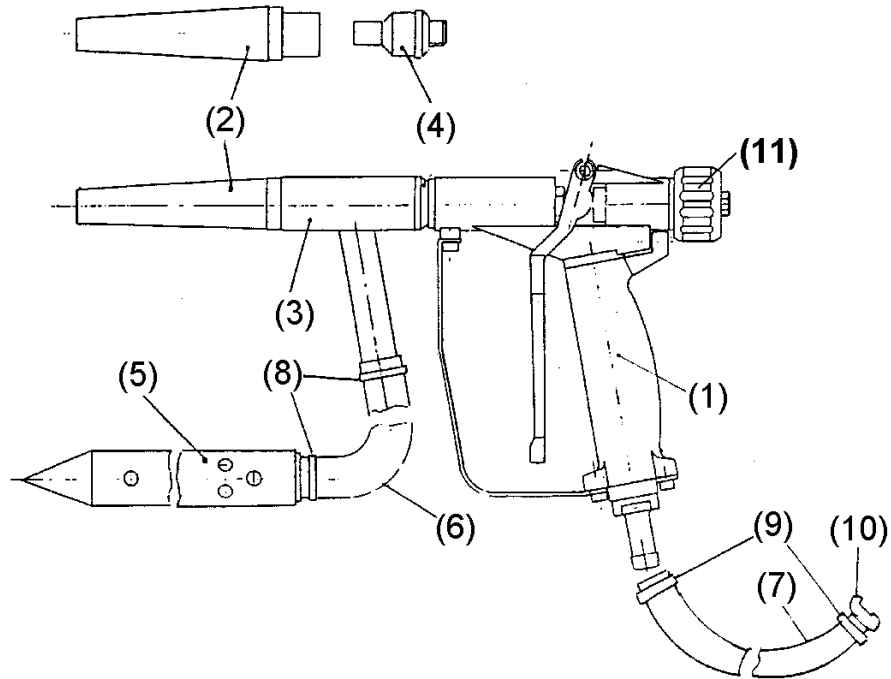

NO.	STOCK NO.	DESCRIPTION
(-)	99860D	Power-injector gun complete with cart and hopper, 5m hoses
(-)	90253D	Power injector gun complete, without cart and hopper, 5m hoses
(1)	90208D	Body
(2)	90209D	Nozzle
(3)	90366D	Mixer
(4)	90213D	Orifice
(5)	90214D	Suction lance
(6)	90042D	Suction hose 1" (per m)
(7)	90045D	Air supply hose (per m)
(8)	90090D	Clamp20-32 for suction hose
(9)	90077D	Clamp 25-40 for air supply hose
(10)	93245D	Coupling SKG-19
(11)	90584D	Handwheel
(-)	90368D	Hopper (not shown)
(-)	90367D	Cart (not shown)
(-)	99899D	Cart with hopper and cover

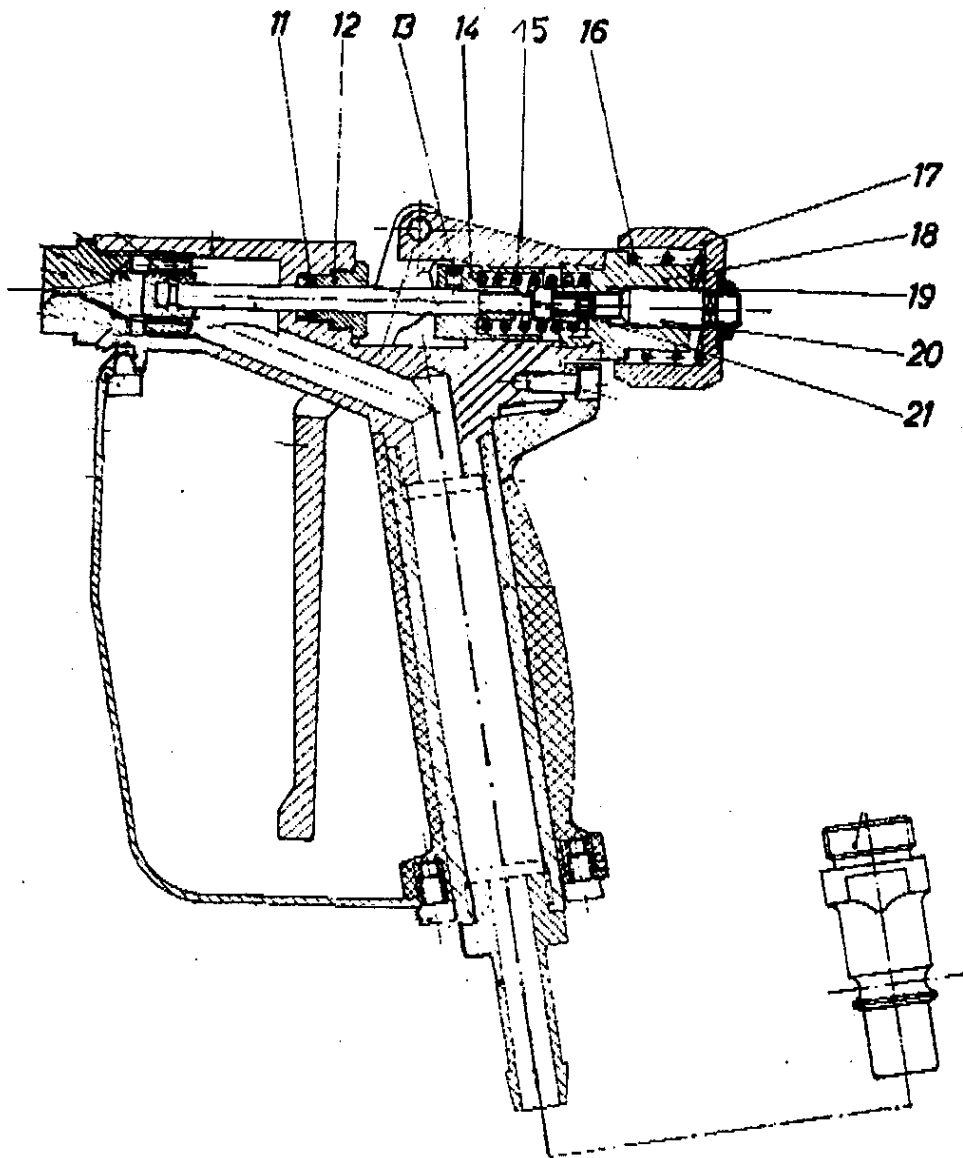

Pos. No:	Part no.:	Description
11	90595D	Gasket power
12	90593D	Plug power
13	90592D	Pin power
14	90591D	Guide power
15	90590D	Spring power piston
16	90589D	Spring power hand-wheel
17	90584D	Air regulator power
18	90585D	Nipple for power
19	90586D	Nut for power
20	90587D	Needle for power
21	90588D	Screw for power