

**Global engineering -  
Trusted solutions**



# ***OWNER'S MANUAL***

## ***Power Injection gun (PIG) "Universal" (with water connection)***

**Clemco**

International GmbH

Carl-Zeiss-Straße 21  
83052 Bruckmühl  
Germany

Tel.: +49 (0) 8062 – 90080

Mail: [info@clemco.de](mailto:info@clemco.de)

Web: [www.clemco-international.com](http://www.clemco-international.com)

## TABLE OF CONTENTS

|            |  |          |
|------------|--|----------|
| <b>1</b>   | <b><i>Scope of manual</i></b>                            | <b>3</b> |
| <b>2</b>   | <b><i>Applications and restrictions</i></b>              | <b>3</b> |
| <b>3</b>   | <b><i>General description</i></b>                        | <b>4</b> |
| <b>4</b>   | <b><i>Operation</i></b>                                  | <b>4</b> |
| <b>4.1</b> | <b>Compressed air consumption</b>                        | <b>4</b> |
| <b>4.2</b> | <b>Set-up for initial installation or reinstallation</b> | <b>4</b> |
| <b>4.3</b> | <b>Daily set-up</b>                                      | <b>4</b> |
| <b>4.4</b> | <b>Set-up and operation</b>                              | <b>5</b> |
| <b>4.5</b> | <b>Shutdown after finishing work</b>                     | <b>5</b> |
| <b>4.6</b> | <b>Shutdown when moving equipment</b>                    | <b>5</b> |
| <b>5</b>   | <b><i>Maintenance</i></b>                                | <b>5</b> |
| <b>5.1</b> | <b>Daily check list</b>                                  | <b>5</b> |
| <b>5.2</b> | <b>Weekly check list</b>                                 | <b>5</b> |
| <b>5.3</b> | <b>Monthly check list</b>                                | <b>5</b> |
| <b>5.4</b> | <b>Air nozzle fitting instructions</b>                   | <b>6</b> |
| <b>6</b>   | <b><i>Troubleshooting</i></b>                            | <b>6</b> |
| <b>7</b>   | <b><i>Replacement parts</i></b>                          | <b>7</b> |

# 1 Scope of manual

This manual covers the operation and maintenance of the "Universal" power injection spray blasting gun.

## 2 Applications and restrictions

The "Universal" power injection spray blasting gun allows spray blasting to be performed in an environmentally responsible way, conservatively, safely and with low operating costs.

### **The "Universal" power injection gun can be used in the following ways:**

- Air and blast media
- Air, blast media and water
- Air and water
- Air

### • **Technical data:**

|  |  |
|--|--|
| Air consumption:   | min 3 m <sup>3</sup> /h (ideal 5 m <sup>3</sup> /min, at 6 bar)  |
| Air pressure:  | up to 12 bar   |
| Water consumption:   | 0 - 2.5 l/min  |
| Blast media consumption:   | 50 - 150 kg/h  |
| Blast media grit size:   | 0 - 1.5 mm   |
| Type of blast media used:  | mostly glass beads, stone dust or clinker  |
| Maximum suction length:  | 10m (standard 5m)  |
| Suction height:  | 3m without any reduction in performance (max. 5m)  |
| Spray and air nozzle:  | wear-resistant tungsten carbide (working life between 200 - 500h)<br>- depending on the air pressure and the type of blast media |
| Area coverage when spraying:<br>substrate (5 - 10 m <sup>2</sup> /h) | varies depending on the degree of contamination and type of  |

### • **Intended purpose:**

The spray gun is suitable for the following work:

- Roughening surfaces
- Dressing weld seams
- Substrate pre-treatment
- Rust removal
- Graffiti removal
- Paint removal
- Cleaning natural stone facades
- Cleaning rendered facades
- Cleaning artificial stone surfaces
- Blasting of concrete reinforcement rods

### • **Adjustment capabilities:**

- Adjustment directly at the gun to suit the air pressure, blast media quantity and water quantity
- for dry blasting
- for wet blasting
- Suitable for all types of blast media (mostly used for glass beads, clinker and stone dust)

### **Note:**

There are two reasons for not re-using blast media:

1. the blast media must be totally dry (and drying it would cost more than buying new blast media)
2. the blast media becomes worn

- **Conservative:**

The "Universal" power injection gun allows conservative spray blasting to be performed, i.e.:

- no water injected into the building structure
- no damage due to water penetration
- blasted surfaces are immediately available for further treatment

- **Safe:**

The flow of blast media, water and air can be stopped instantly.

**Attention! (applies only to dry blasting) In Germany and in many other countries even injection spray blasting guns may not be used outdoors. On environmental grounds, suitable enclosures (such as spray tents with extraction) are required.**

### 3 General description

The arrangement of the "Universal" POWER INJECTION GUN is shown in the diagram (see Section 8). Pressing the deadman's handle on the body of the gun (item 1) allows compressed air to flow through the air nozzle (item 4). This expands in the mixing chamber (item 3) causing a partial vacuum which sucks the blast media from an open container through the suction lance (item 5) and the suction hose (item 8). This flow of blast media is picked up by the compressed air flow and accelerated up to working velocity at the spray nozzle (item 2).

The suction lance (item 5) is arranged to ensure an even flow of blast media.

At the injection head (item 14) the pressure is reduced only sufficiently to allow water from the public water mains to be fed in.

### 4 Operation

#### 4.1 Compressed air consumption

| Air pressure [bar]                    | 3   | 4   | 5   | 6   | 7   | 8   | 9   | 10  | 11  | 12  |
|---------------------------------------|-----|-----|-----|-----|-----|-----|-----|-----|-----|-----|
| Air consumption [m <sup>3</sup> /min] | 2,4 | 3,0 | 3,6 | 4,2 | 4,8 | 5,4 | 6,1 | 6,7 | 7,3 | 8,0 |

#### 4.2 Set-up for initial installation or reinstallation

The "Universal" POWER INJECTION GUN is supplied ready to use. It just needs to be connected to the compressed air and water supply.

#### 4.3 Daily set-up

- (1) Before starting spraying, check that
  - all connections and hose clips are tight.
  - there is no undue wear evident on the suction hose or air hose.
  - there is sufficient light and the field of view is clear.
  - there is sufficient room to work.
- (2) Connect the compressed air hose.
- (3) Connect the water hose
- (4) Insert the suction lance into the container. **Make sure that the air holes at the top of the suction lance where it is connected to the suction hose are outside the container.**
- (5) Put on your protective equipment
  - Blast suit.

- Leather gloves.
- Air-fed helmet with breathing air filter.

#### **4.4 Set-up and operation**

1. Unpack the spray gun and identify any damage suffered in transport
2. Fit the accessories

Attach hoses 6 and 7 to the hose clips 8 and 9

3. Connect the compressed air

Connect the air hose (7) to the compressor using the hose coupling

Check that the coupling is correctly seated

4. Connect the water

For connection values see ("Technical data")

The water feed hose (16) is connected to the spray gun and to the water supply.

The water must be supplied at a pressure of at least 2 bar.

**Note:**

Comply with your water supply company's regulations.

DIN 1988 specifies that the spray gun may not be connected directly to the public drinking water supply.

Connection for short periods is permissible providing a non-return valve is used.

#### **4.5 Shutdown after finishing work**

- (1) Take the suction lance out of the blast media container, and clear the remainder of the blast media from the suction hose by suction.
- (2) Switch off the external compressed air supply.

#### **4.6 Shutdown when moving equipment**

No special action is required.

### **5 Maintenance**

Spray blasting guns are subject to wear during operation. To ensure safety and maintain high efficiency, spray guns must be serviced regularly according to the following check lists.

**Before servicing is started, the air feed from the compressor must be shut down and the entire system depressurised!**

#### **5.1 Daily check list**

- (1) Check that the hose clips are tight.

#### **5.2 Weekly check list**

- (1) Check the suction hose for wear.
- (2) Check the compressed air hose for wear.
- (3) Check the spray nozzle for wear. Note that a 10% increase in diameter corresponds to a 20% reduction in efficiency.

#### **5.3 Monthly check list**

- (1) Check the mixing chamber for wear. If it is heavily worn, replace it without delay.
- (2) Check the air nozzle for wear. This requires removal of the mixing chamber. Even small changes in the length of the air nozzle cause significant loss of efficiency.

## 5.4 Air nozzle fitting instructions

To obtain the best performance by the spray gun, the nozzle must be fitted as shown in the sketch below.

- 1 = PIU mixing chamber
- 2 = PIU nozzle collar
- 3 = PIU air nozzle liner

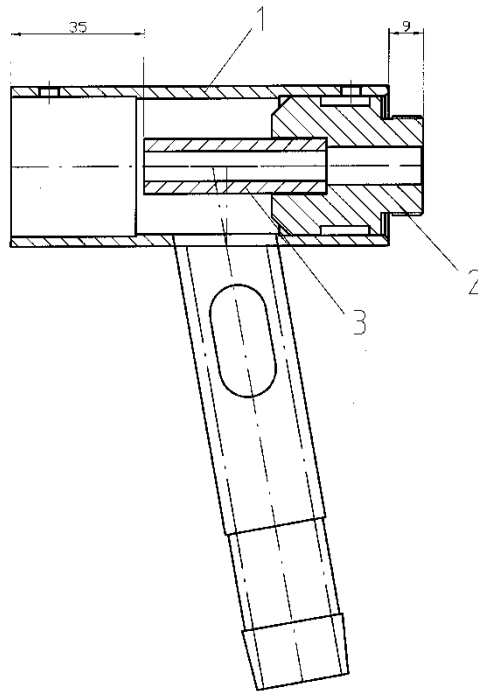

## 6 Troubleshooting

| <b>Symptom</b>  | <b>Possible cause</b>   | <b>Remedy</b>   |
|---|---|---|
| (1) Air comes out of the nozzle but no blast media.                         | Blast media damp or blocked.  | <ul style="list-style-type: none"> <li>– Close the spray nozzle outlet by pressing it hard against a resilient surface such as a leather glove. Depress the deadman's handle. The air stream then swirls around and cleans the affected parts.</li> <li>– Only if that fails should the suction lance, the suction hose and the mixing chamber be cleaned.</li> <li>– Replace the blast media.</li> </ul> |
|   | External air is being drawn in.   | <ul style="list-style-type: none"> <li>– Tighten the clips on the suction hose.</li> <li>– Close the blast media regulating valve (19).</li> <li>– Replace the suction hose and mixing chamber if worn.</li> </ul>  |
| (2) No air  | Air valve at the compressor closed<br>Defective compressor  | <ul style="list-style-type: none"> <li>– Check the connection to the compressor, open the valve</li> <li>– Contact the compressor manufacturer's customer service</li> </ul>  |
| (3) No water is mixed in, despite water being available at the water supply | <ul style="list-style-type: none"> <li>– Regulating valve (15) closed</li> <li>– Insufficient water pressure</li> <li>– (&lt; 2 bar)</li> <li>– Blockage in the water system</li> </ul> | <ul style="list-style-type: none"> <li>– Close the air nozzle outlet (the mixing chamber (3) must be removed) by pressing it hard against a resilient surface</li> </ul> <p>If this does not solve the problem:</p> <ul style="list-style-type: none"> <li>– Remove the water valve</li> </ul>  |

## 7 Replacement parts

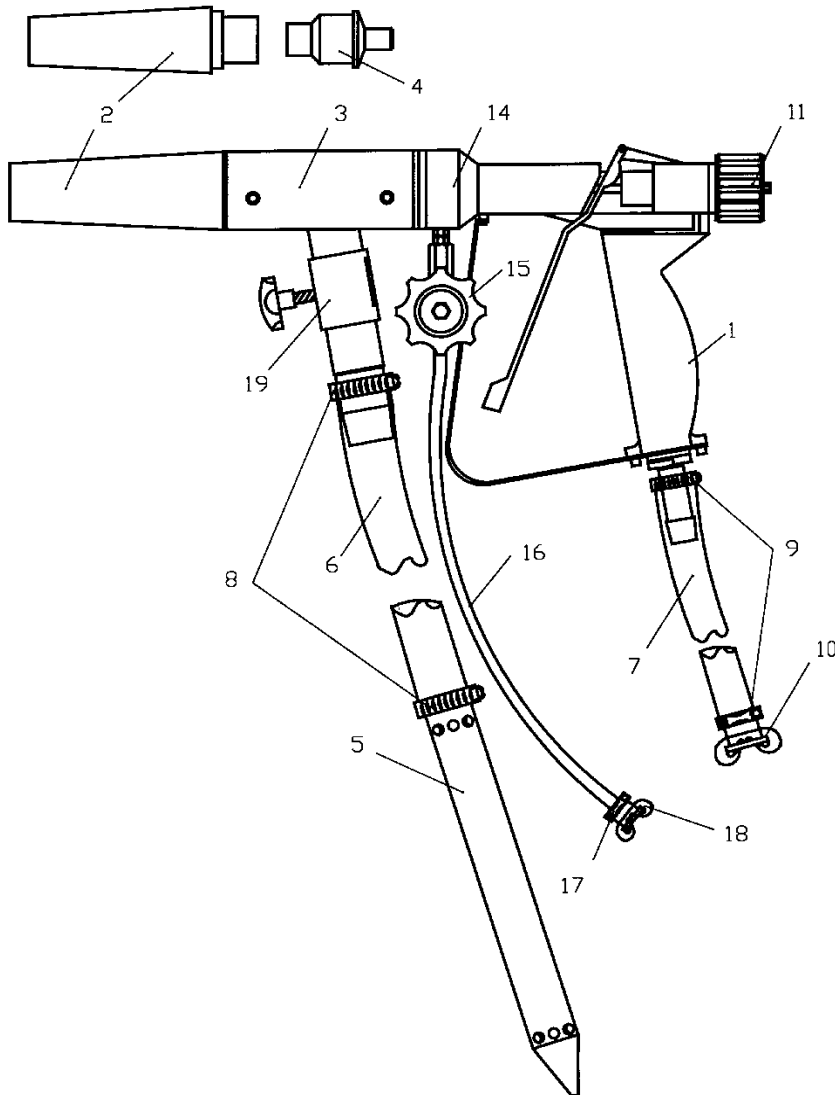

### Ordering data

| Item no.  | Stock no.     | Designation              |
|-----------|---------------|--------------------------|
|           | <b>100489</b> | Power Injection Gun      |
| <b>1</b>  | <b>90208D</b> | Gun body                 |
| <b>2</b>  | <b>90209D</b> | Nozzle                   |
| <b>3</b>  | <b>100491</b> | Power Uni mixing chamber |
| <b>4</b>  | <b>100490</b> | Power Uni air nozzle     |
| <b>5</b>  | <b>90214D</b> | Suction lance            |
| <b>6</b>  | <b>90042D</b> | Suction hose             |
| <b>7</b>  | <b>90045D</b> | Air hose                 |
| <b>8</b>  | <b>90090D</b> | Hose clip 20-32          |
| <b>9</b>  | <b>90090D</b> | Hose clip 20-32          |
| <b>10</b> | <b>93245D</b> | SKG19 hose coupling      |

| Item no.  | Stock no.     | Designation               |
|-----------|---------------|---------------------------|
| <b>14</b> | <b>100496</b> | Power Uni injection head  |
|           | <b>100495</b> | Power Uni water injector  |
|           | <b>085311</b> | NW-0 Power UNI gasket     |
| <b>15</b> | <b>100485</b> | Regulating valve ¼"       |
| <b>16</b> | <b>100464</b> | Hose 6 mm                 |
| <b>17</b> | <b>90078D</b> | Clip 11-13                |
| <b>18</b> | <b>100484</b> | GKI-14 coupling           |
| <b>19</b> | <b>100492</b> | Power Uni locking ring    |
|           | <b>100493</b> | Star grip M6 X10          |
|           | <b>100494</b> | Screw (hexagon head) M4X5 |